

FR 785.ECD

SLIDE TYPE:	Full-Extension Drawer Slide-Progressive-Action with Easy Close Device
MOUNTING:	Side Mount

WIDTH:	18 mm (0.71 in.)
LOAD	dynamic up to 55 kg (125 lbs) full-ext.
CAPACITY:	dynamic up to 45 kg (100 lbs) over-ext.

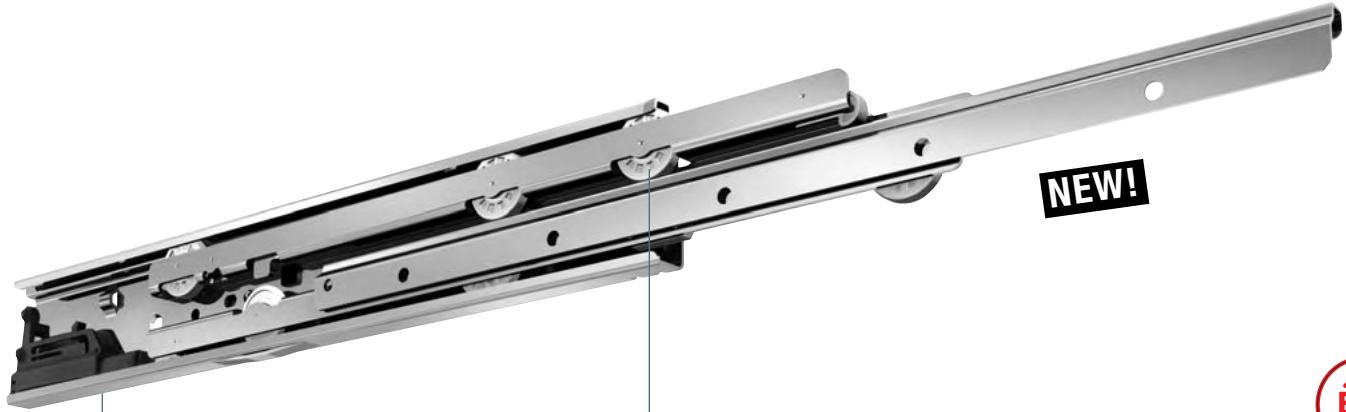

MATERIAL: steel, zinc plated, powder coated

FEATURES: solid delrin* rollers

- SPECIFICATIONS:**
- ▶ cabinet and drawer profile with screw holes
 - ▶ high lateral stability through specially formed middle profile and guide rollers
 - ▶ ideal running characteristic and smoothness of running through integrated progressive-action
 - ▶ safety clip mounted in middle profile
 - ▶ double-sided captive profile
 - ▶ ECD Easy Close Device
 - ▶ soft stop

- NOTES:**
- ▶ on request a compatible regular-extension drawer slide is available
 - ▶ on request available with 60 mm (2.36 in.) over-extension

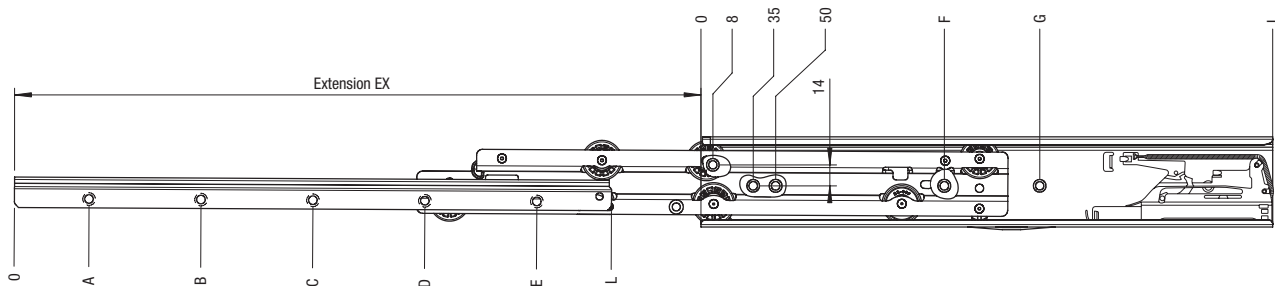
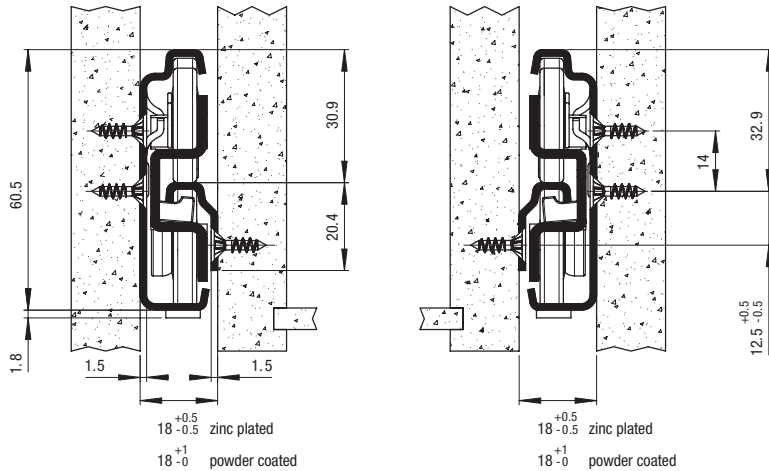

Length L	EX		EX		A	B	C	D	E	F	G	Order No.	Order No.	Order No.	Order No.								
	mm	in	full-ext. mm	in												over-ext. mm	in						
367	14.45	335	13.19	410	16.14	28	1.10	156	6.14	316	12.44	163	6.42	291	11.46	*	*	*	*				
417	16.42	385	15.16	460	18.11	28	1.10	156	6.14	380	14.96	163	6.42	355	13.98	*	*	*	*				
467	18.39	435	17.13	510	20.08	28	1.10	156	6.14	316	12.44	412	16.22	163	6.42	355	13.98	*	*	*	*		
517	20.35	485	19.1	560	22.05	28	1.10	156	6.14	348	13.70	476	18.74	163	6.42	355	13.98	*	*	*	*		
567	22.32	535	21.06	610	24.02	28	1.10	156	6.14	348	13.70	508	20.00	163	6.42	355	13.98	*	*	*	-		
617	24.29	585	23.03	660	25.98	28	1.10	156	6.14	348	13.70	572	22.52	195	7.68	355	13.98	*	*	*	*		
667	26.26	635	25.00	710	27.95	28	1.10	156	6.14	348	13.70	604	23.78	163	6.42	355	13.98	*	*	*	-		
717	28.23	685	26.97	760	29.92	28	1.10	156	6.14	348	13.70	540	21.26	668	26.30	163	6.42	355	13.98	*	*	*	*
767	30.20	735	28.94	810	31.89	28	1.10	156	6.14	348	13.70	572	22.52	732	28.82	163	6.42	335	13.98	*	*	*	*

Packing Unit: **5 pair per box**

*** on request**

*DuPont (TM) Delrin®