





## Supplied Parts List

- A** Drawer Slide, left (cabinet, middle and drawer profile with integrated ECD).
- B** Drawer Slide, right (cabinet, middle and drawer profile with integrated ECD).
- C** Bottom Mount Brackets
- D1** Connecting Bracket
- D2** Connecting Bracket with slot
- D3** Support profile, left
- D4** Support profile, right
- F** Tray (1 piece).
- G** Wire Support (1 piece).

## Screws:

-  (g) M4 x 8mm, zinc
-  (h) M4 Nut, zinc
-  (i) M4 x 8mm, zinc
-  (j) No. 8 x 5/8 in., zinc
-  (n) Washer



FR 3610



FR 3610

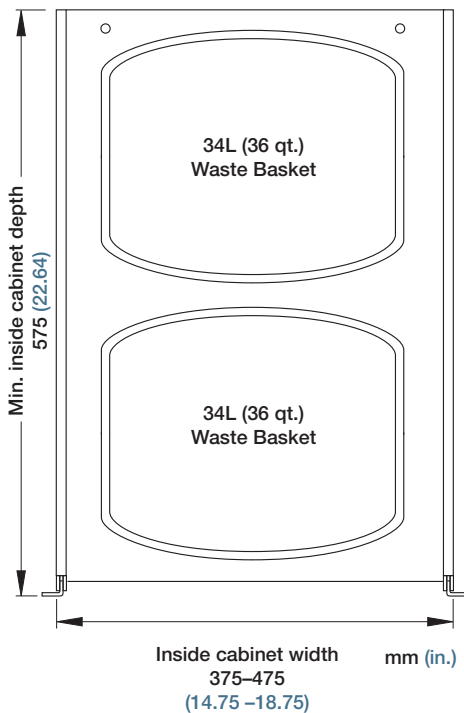
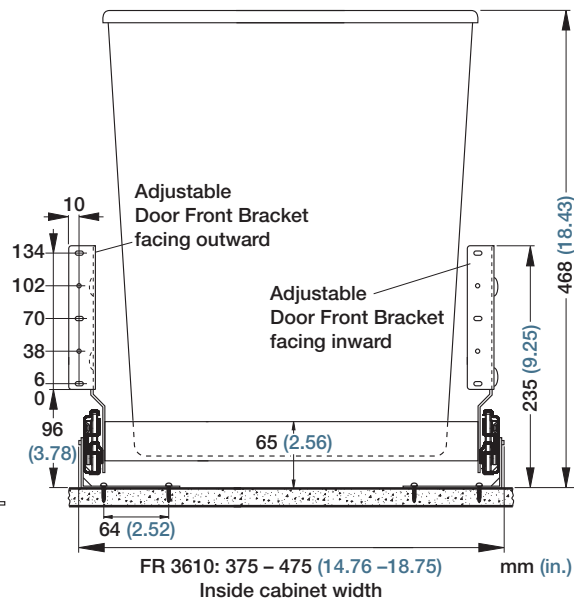
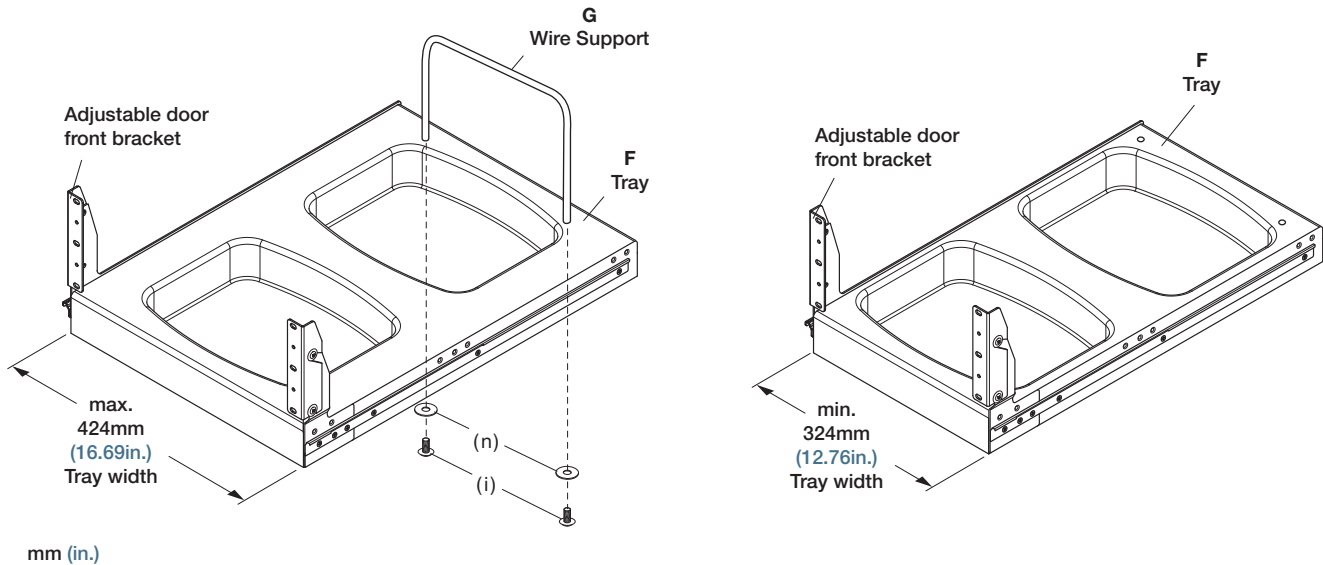

Figure 1



**Step 1.** Identify all parts. The build-in width of the unit is set to its maximum of 476mm (18.75 in.) with tray **F** at 424mm (16.69 in.). If you are faced with a narrower cabinet inside width you have the option of cutting tray **F** down to the required size on a table saw. Be sure to cut away equal amounts from each side to a minimum tray width of 324mm (12.76 in.) and a minimum build-in width of 375mm (14.76 in.). Make appropriate width adjustment to the connecting brackets **D1** and **D2** (figure 2).



**Step 2.** Mount cabinet profiles **A** and **B** to the floor of the cabinet with screws **(j)** (figure 1, 2 and 3). Make sure that slides are parallel and perpendicular to the front edge. Determine the back set from the front edge of the cabinet by the thickness of the bumpers on the door panel.

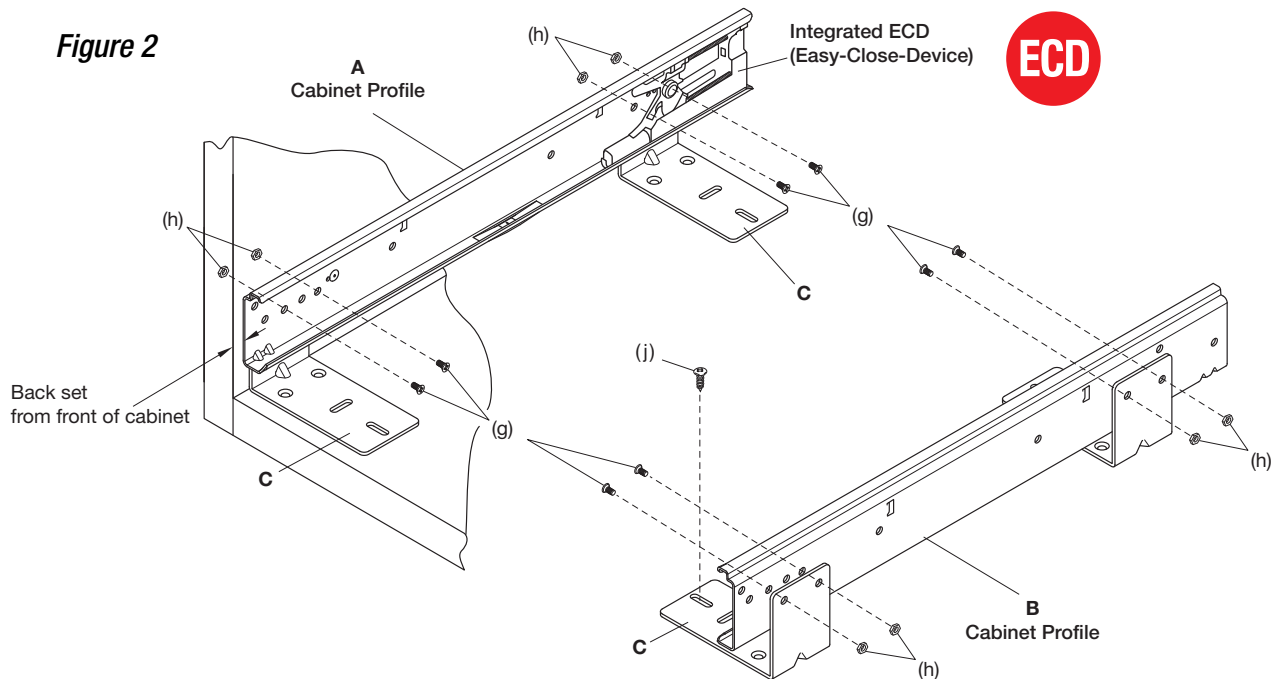
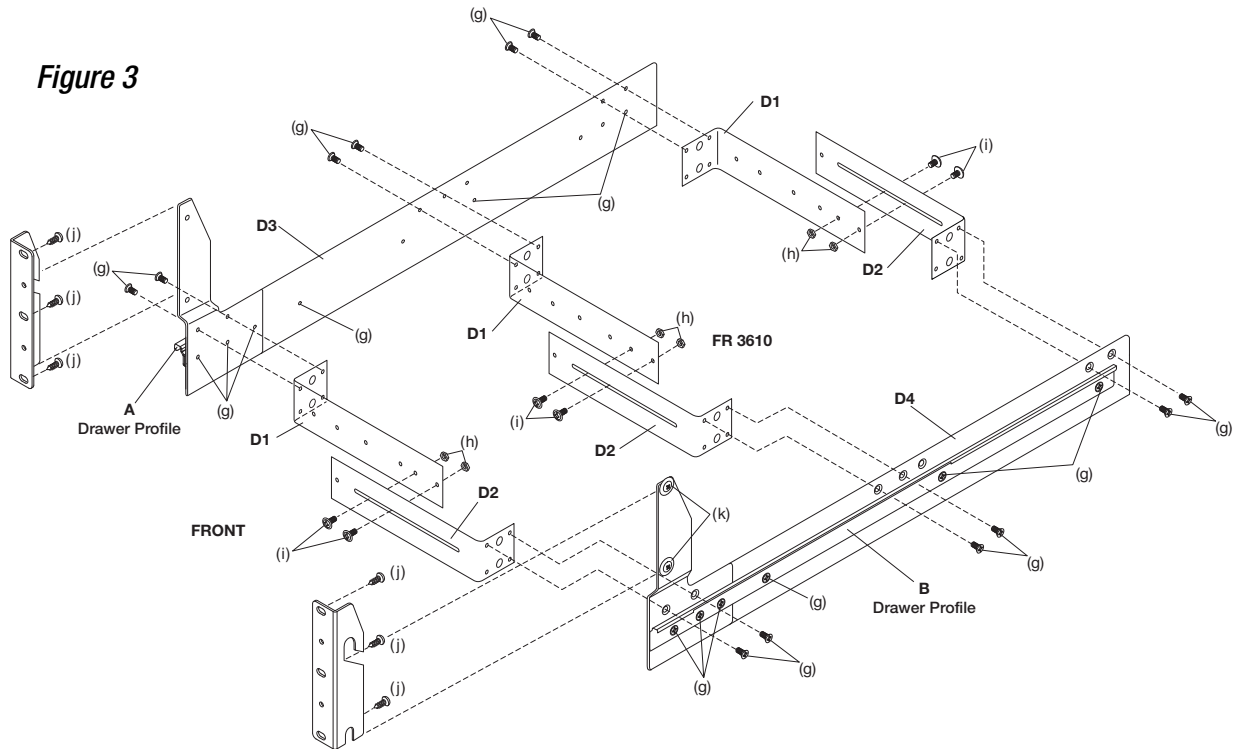

Figure 3



**Step 3.** Determine the location of the door front bracket using figure 1. Attach door with screws **(j)**. Adjust alignment screws **(k)**.

### ECD Assembly

#### 1., 2., 3. and 3.1.

Position the ECD as illustrated flush with the end of the slide. Be sure that all parts clip in their appropriate location.

