

FR 1020

SLIDE TYPE:	Regular-Extension Drawer Slide
MOUNTING:	Side Mount

WIDTH:	12 mm (0.47 in.)
LOAD CAPACITY:	dynamic up to 34 kg (75 lbs.)



MATERIAL:	powder coated cold rolled steel
------------------	---------------------------------

FEATURES:	solid Delrin* rollers
------------------	-----------------------

SPECIFICATIONS:

- ▶ lateral stability provided by specially shaped profiles
- ▶ integrated side adjustment - clearance adjustable up to 2 mm
- ▶ double hole system on cabinet profile for offset attachment to thin inside walls
- ▶ added strength of cabinet profile provided by special front flange
- ▶ oblong holes in the cabinet profile permit easy height adjustments
- ▶ dual detent in the drawer profile holds the drawer in place when extended
- ▶ single-sided captive profile (left)

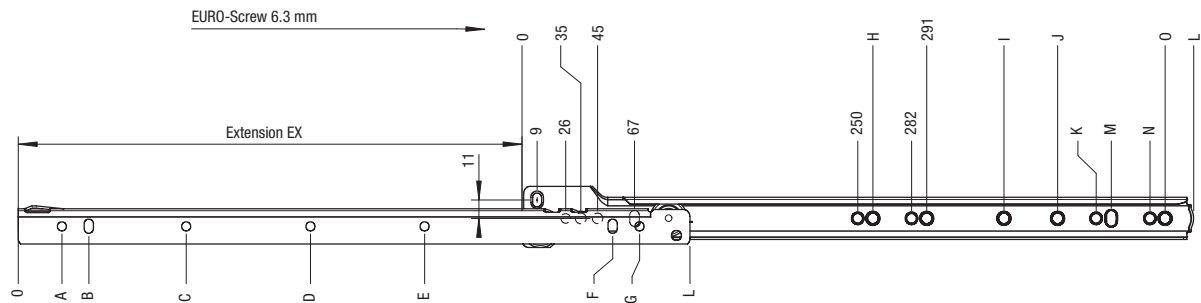
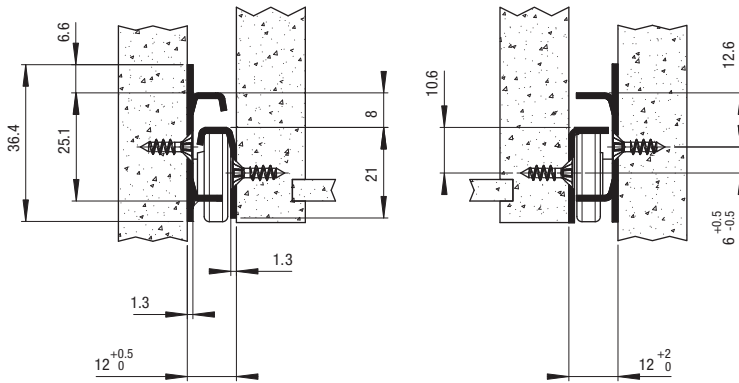

Length L	EX	A	B	C	D	E	F	G	H	I	J	K	M	N	O	Weight per pair	Order No.	
mm in	mm in	mm in	mm in	mm in	mm in	mm in	mm in	mm in	mm in	mm in	mm in	mm in	mm in	mm in	mm in	kg lbs	white	
300 11.81	215 8.47	46 1.81	62 2.44	142 5.59			254 10.00	270 10.63					259 10.20			0.49 1.08	3009	
350 13.78	265 10.43	32 1.26	48 1.89	192 7.56			304 11.97	320 12.60		323 12.72			259 10.20			0.56 1.23	3010	
400 15.75	300 11.81	50 1.97	66 2.60	242 9.53			354 13.94	370 14.57	259 10.20	355 13.98			378 14.89	387 15.24		0.63 1.39	3011	
450 17.72	350 13.78	36 1.42	52 2.05	292 11.50			404 15.91	420 16.54	259 10.20	387 15.24			410 16.14	419 16.50	442 17.40	0.70 1.54	3012	
500 19.69	400 15.75	22 0.87	38 1.50	150 5.91	342 13.47		454 17.87	470 18.50	259 10.20	387 15.24	419 16.50		442 17.40	451 17.76	474 18.66	483 19.02	0.78 1.72	3013
550 21.65	430 16.93	40 1.57	56 2.21	200 7.87	392 15.43		504 19.84	520 20.47	259 10.20	483 19.02			506 19.92	515 20.28	538 21.18		0.83 1.83	3014
600 23.62	480 18.90	26 1.02	42 1.65	250 9.84	442 17.40		554 21.81	570 22.44	259 10.20				506 19.92	515 20.28	538 21.18	547 21.54	0.92 2.03	3015
650 25.59	530 20.87	44 1.73	60 2.36	300 11.81	492 19.37		604 23.78	620 24.41	259 10.20				506 19.92	515 20.28	538 21.18	547 21.54	0.99 2.18	3016
700 27.56	560 22.05	30 1.18	46 1.81	190 7.48	350 13.78	542 21.34	654 25.75	670 26.38	259 10.20				506 19.92	515 20.28	538 21.18	547 21.54	1.06 2.34	3017

Packing Unit: 20 sets per box

*DuPont (TM) Delrin®